

Coating of tablets and multiparticulates



Dr. Isra Dmour

Credit: Prof. Nizar Al-Zoubi

1

1

Coating of tablets and multiparticulates

الcoating : أنت حضرتت tablet ويدك
تضيف عليها layer معينة

- Tablet coating is the application of a coating material to the exterior of a tablet with the **intention** of conferring benefits and properties to the dosage form over the uncoated variety →

شيء متعدد ، يدك تستفيد
فوائد معينة ، واحنا حكينا انه
اي خطوة لها cost فما
بتعمل اشي الا اذا الة فوائد

- Coating can be applied to:
 - Tablets (the most commonly coated dosage form)
 - Capsules
 - Multiparticulates →
 - Drug crystals

الspansules او pellet هذول كبسول
بكون فيهم لونين او ٣ الوان ، بس تعمل
coating بتغير الrelease يعني ممكن
تكون نفس المادة immediate و
sustained ، ويمكن يكون في ٣ مواد
ويصير interaction بينهم فالcoat
بمنع هاد الinteraction

شي فوائدده؟

وبيسهل البلع ، release لل Protection ،
ويقدر المريض يميز بين الادوية اذا كان لون ، و
تغطية الطعم اذا كان طعم الدواء سيء او بترك
اثر .

لازم يكون في اسباب للcoating ، اذا
ما في سبب بضل عالuncoated

2

2

1

Coating of tablets and multiparticulates

هاد نوع قديم زي ال m&m's, الصناعات الدوائية اخدوها من صناعة الحلويات ، اخدوا المواد والاجهزة وطوروا عليها Sugar coated tablets ↗

Types of coating

There are three main types of coating:

Dominant 1. Film coating: for tablets, multiparticulates, capsules, ..

2. Sugar coating

3. Press (Compression) coating

2 & 3 For tablets only

Film coated tablets



صافين لعمقة / هين مطفين

Sugar coated tablets ↗



لمعة



more spherical tablet sugar coating ليعمل لما تكبر (tablets) اذا فيها زياد اذنا ليع اذ Crown / اذا فيها خط كبر ما يصل sugar coating

3

فقط لا Tablet

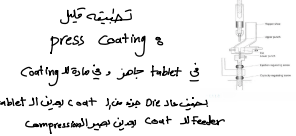

3

Film - يعمل لكلي نوع 30 ما كان ال شكل ، على ما عانت اظلام المبر يتزوج لا Film

العلامة الشائعة انه هاد في لمعة shine يتميز بينهم بدون tests

Features	Sugar coating	Film coating
<i>Tablets</i>		
Appearance	Rounded with high degree of polish / shiny	Retains contour of original core Usually not as shiny as sugar coat types
Weight increase due to coating materials	30-50%	2-3%
Logo or 'breaklines'	Not possible	Possible
Other solid dosage forms	Coating possible but little industrial importance	Coating of multiparticulates very important in modified-release forms
<i>Process</i>		
Stages	Multistage process 20-30	Usually single stage
Typical batch coating time	8 hours, but easily longer	1.5-2 hours
Functional coatings	Not usually possible apart from gastro-resistant (enteric) coating	Easily adaptable for controlled release

اذا فيها زياد اذنا / تقابل Contour ما يعمل sugar

4

Syrup ال sugar ليع = immediate ليع water Soluble فسي non functional

4

Reasons for coating of tablets and multiparticulates

1. To provide protection of drug from environment, especially light and moisture

2. To mask taste, odor or color of the drug في اللون غير متجانسة / في الازهار والذوق

3. Masking any batch difference in the appearance of raw materials بس اكيس واهون حبة بالبراية يكون لونها

4. To modify drug release: Coating من لون واحد من اجل Coating

• Delayed release (ex. enteric coating to protect the drug from the gastric environment of the stomach or the stomach from irritation caused by some drugs)

• Extended release properties. احضرت 12h / 24h / 3 ايام او اسبوع

5. To aid in identification of product (i.e. colored coating) خاصة للمرضى chronic فوضه ادوية كغيره ليعرف

6. To improve tablet elegance ارادوا خاصه اذا كان

7. To facilitate tablet swallowing يمكن اذا يدك تبلع uncoated تكون ناشئة

8. To enable easier handling during high-speed filling and packaging of the coated product (improve product flow, increase mechanical strength, minimize dust formation)

↓
uncoated

Coating ال يمنع التكبير والقطر خلال ال Filling وال packaging

5

لصبر احتكاك وبقوا dust
Contamination

Film coating = polymer

• Film coating is the most modern and generally used method nowadays.

• Nearly all newly launched coated products are film coated rather than sugar coated.

• Depending on the materials used in coating it is either for:

– immediate release (non-functional coating) or water soluble : Film ال

– modified (delayed or extended) release (functional coating).

اله دور بار release

6

6

Film coating

Advantages of film coating

- 1) Reduction in coating time حَبَقَتَيْنِ أَوْ حَبَقَةً
- 2) Usually single stage
- 3) Small increase in tablet weight زِيَادَةٌ بِالْوِزْنِ 2-3%
- 4) No significant increase in disintegration time الطَّبَقَاتِ قَلِيلَةً / مَا فِيهِ اِخْتِلَافٌ كَثِيرٌ
- 5) Less chipping and cracking بِالزَّمَنِ بِإِلَّا Disintegration بعد الـ coating

بمجرد ما من الامهض الم خلال التعبئة

7

7

Film coating

Coating suspension formulation

blind of 2 or 3 polymers ممكن

- Polymer (Film former) ↑ Formula نزي الى بمهنية 1
- Plasticizer
- Color ممكن بدون
- Solvent (water) solvent في Container -

(Ethanol) organic solvent
isopropanol
اسيتون

branch n liner
liner

polymer : Chain طويلة جداً ومتشابكة و rigid ف ال plasticizer يخلي ال polymer

8

تشكل على شكل rigid tablet مع لزوايا والخطوط / فهو مادة يتخلل بين ال chains وتخليها مرنة بدل ما هي rigid

4

Film coating polymers

Ideal characteristics of a film forming polymer

Solubility

- Polymer solubility is important for two reasons: إذا water soluble ال release سريع
 - It determines the behavior of coated product in the GIT.
 - It determines the solubility of the coating in a chosen solvent system
- Film coatings that are used in immediate release products have usually good solubility in aqueous fluids, while those used for modified release have limited or no solubility in aqueous media.

إذا بي ال immediate release ال solvent له لم يكون water

9

9

Film coating polymers

Ideal characteristics of a film forming polymer

Viscosity

- Polymers applied as solutions in a selected solvent should have relatively **low viscosity**. Coating ال سهل بال تشكيل وبال tablet حلين ال low viscosity
- High viscosity complicates the product transfer of the coating liquid from the storage vessel to the spray guns, and subsequent atomization.

=
spraying

10

كيفي اتحكم بال viscosity ؟ اقلها

أو ① يا بسخن
② اقل التركيز

10

5

Film coating polymers

Ideal characteristics of a film forming polymer

Permeability

- Film coating can be used to optimize the shelf-life of a tablet preparation, as some polymers are efficient barriers against the permeability of water vapour or other atmospheric gases. *expmulate*

- These properties vary widely between the individual polymers.

➤ Polymers for extended release coating should be permeable to water (and drug in conventional systems) *بمن مثن لدرجة تمتص الرطوبة خلال التخزين*

لازم في توازن بلا permeability ، خلال التخزين لازم non permeable مايتأثر بالرطوبة / اما لما يحصل

للعدة لازم ليغير ¹¹ release فلزم يكون permeable عشان ال gastric media تدخل ← Dissolution ← drug diffusion

Film coating polymers

Ideal characteristics of a film forming polymer

Mechanical strength

Film-coating polymers should possess suitable characteristics with respect to:

- Film strength**, which greatly affects the ability of the coating to resist the mechanical stresses to which it will be exposed during the coating process and during subsequent handling of the coated product. *الخطوة الأولى ← بعدها تعبئة*
- Film flexibility**, which imparts similar benefits to film strength and minimizes film cracking during handling or subsequent storage. *فلا coating يمنع اي*
- Film adhesion**, which is necessary to ensure that the coating remains adherent to the surface of the dosage form right up to the point of being taken by the patient. *مافي defect ال coat خطيها تمام*

لازم ↓ completely adhere على tablet / مثن ببحوية ليقدر ليضمهم لدهن ال Film

polymers عبارة عن chain متداخلين ولما يتشكلوا حولين ال tablet اذا كان ال Film coating ممتاز ما يكون

في اي مجال يدخل فيها اي شيء فينتهي mechanical strength ال tablet

Film coating polymers

Ideal characteristics of a film forming polymer

The film forming material (polymer) should also have the following characteristics:

- It should be capable of producing a continuous elegant and smooth film. *تخليق كامل بدون defects و smooth يكون*
- It should be essentially with no color, taste or odor. *غالباً يكون بيضاء و coated*
- It should be compatible with common coating additives *ما لازم يكون في interaction*
- It should be nontoxic and pharmacologically inert *inert لانه مش مناسب لمرض السكري*
- It should be stable in the presence of heat, light, moisture, air, and the substrate being coated (no change with aging).

ال strands تلتصق polymer بالديايم تكون متماسكة و مع لزني
تترتخي و بتسليق تسعدف بجمها ، المتكدة يكون لمار polymer يكون

اصله طبيعي لانه يكون مناسب للكثيرا توكلها و ال fungi فبصير في Defects

13

13

Film coating

- Combination of polymers may be used to modify the film properties.

- Many water insoluble polymers are available as aqueous dispersions.

المادة الي بي عمل منها coating يا solution / organic solvent water soluble polymer احضر لوبي dispersion

- Some polymers are efficient barriers against the permeability of water vapor and atmospheric gases, therefore they can be used to increase the shelf-life of tablets

الاحتراستي O₂

خاصة اذا كان لدوا يتأكسد

تلازم احمه من الرطوبة و الاكسدة

14

14

Types of film forming polymers

Polymers for immediate release

حفظاً كله

- Cellulose derivatives semi synthetic
 - Hydroxypropyl methylcellulose
 - Soluble in aqueous media and organic solvents
 - Form good films
 - Methylcellulose
 - Hydroxypropylcellulose
 - Hydroxyethylcellulose
 - Methylhydroxyethylcellulose
- Vinyl derivatives synthetic
 - Povidone (polyvinyl pyrrolidone, PVP)
 - Copovidone (A copolymer of vinyl pyrrolidone and vinylacetate)
 - Polyvinyl alcohol (PVA): exhibits good barrier properties to environmental gases and water vapor
- Polyethylene glycols
- Aminoalkyl methacrylate copolymers (Eudragit E®)

ال cellulose عبارة عن saccharide polymer

وال glucose هو ال polymer الرئيسي

COOH تتأين

15

15

ال glucose في مجموعتي CH₂OH و OH همدون ال 2OH قابلية للتخيل

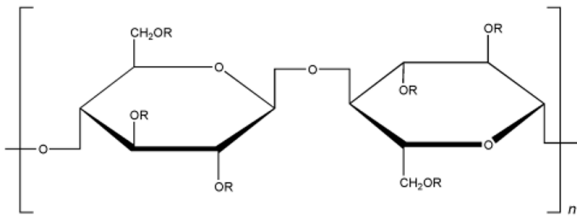

where R is H, CH₃, or CH₂CH(OH)CH₂

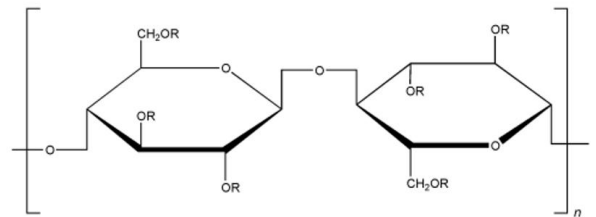

R is H or [CH₂CH(CH₃)O]_mH

ال OH مكنونة في water soluble

(Hydroxypropyl)methylcellulose (Hypromellose, HPMC) وال OH بتأين

Hydroxypropylcellulose

ما في methyl بس في H او hydroxy propyl

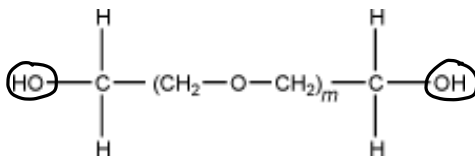

Polyethylene glycols

water soluble

16

16

كله مطلوب

Types of film forming polymers

Sustained release polymers

لا يذوب في الماء water solubility

R: Ethyl

- Cellulose derivatives
 - Ethylcellulose
 - Cellulose esters (cellulose acetate, cellulose acetate butyrate)
- Methylmethacrylate copolymers (Eudragit RS[®], Eudragit RL[®])
- Silicon elastomers *water insoluble*
- Polyvinyl acetate

17

17

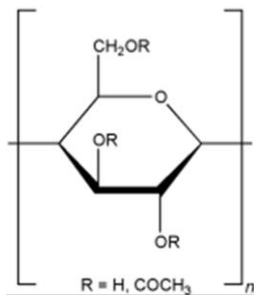

Cellulose acetate

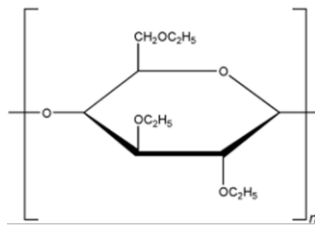

Ethylcellulose

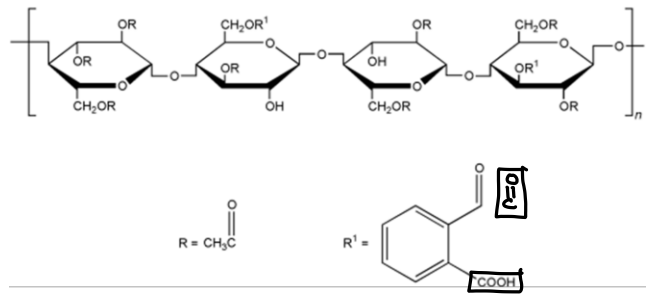

Cellulose acetate phthalate

aromatic

18

18

Types of film forming polymers

Enteric materials

- Phthalate esters
 - Cellulose acetate **phthalate** (CAP)
 - Polyvinyl acetate **phthalate** (PVAP)
 - Hydroxypropyl methycellulose **phthalate**
- Cellulose acetate trimellitate (CAT)
- Methacrylic acid copolymers (Eudragit L[®], Eudragit S[®])
- Carboxymethyl ethylcellulose (CMEC)
- Hydroxypropyl methycellulose acetate **succinate** (HPMCAS)

acid يتركب organic يعني COOH

water soluble ↓ phenyl ↑ organic groups ↑ *

في 2 COOH رسمته *

19

19

Enteric coated ↑ phthalate ↑ *

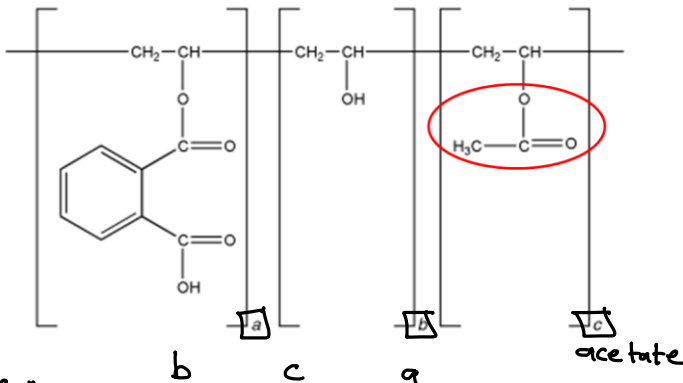

Polyvinyl acetate phthalate

Depending on the phthalyl content, a will vary with b in mole percent. →

The acetyl content c remains constant depending on the starting material.

Variation حسب ال phthalate في المحتوى

حسب هاي النسب بتغير خصائصهم

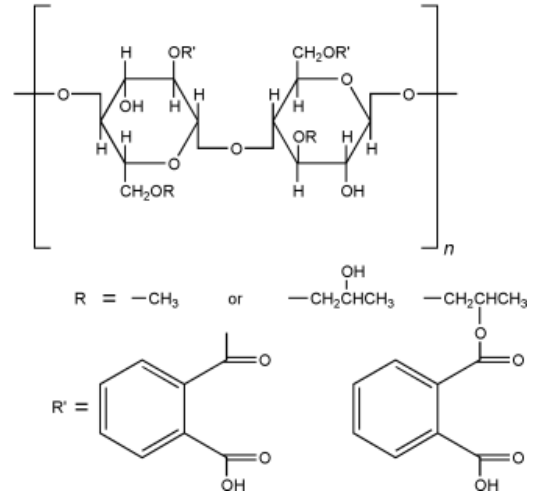

Hydroxypropyl methylcellulose phthalate

20

phthalate عبارة عن phenyl و COOH *

protonated \boxed{COOH} pH = 1.2 بالحمية

release $\boxed{COO^-}$ pH = 6.8 intestinal

↓ Deprotonated لانما في H بالمكان = Enteric release

10

* محلولون يتخرف عليهم بالتفصيل

Eudragit مائي بنزين } water soluble
 } sustained
 } Enteric

Ionization ↑
 Soluble ↑
 Enteric نجيل
 COOH زي
 OH

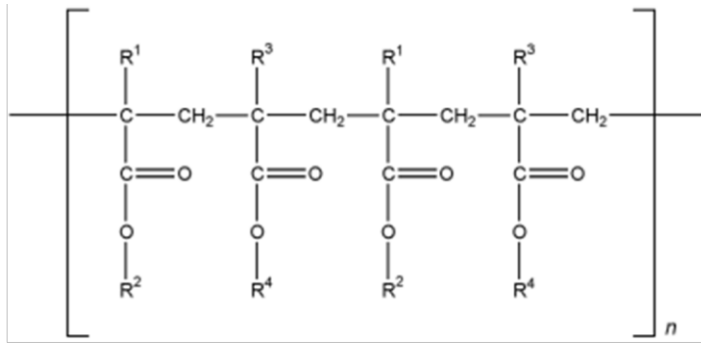

بعد اللابيد
 مشكل اسن كعبته ما عرفت مين بتحكى

For Eudragit E:

R1, R3 = CH3
 R2 = CH2CH2N(CH3)2
 R4 = CH3, C4H9

3° amine - unionized

For Eudragit L

and Eudragit S: → مائي amine
 R1, R3 = CH3
 R2 = H
 R4 = CH3

For Eudragit RL and Eudragit RS:

R1 = H, CH3
 R2 = CH3, C2H5
 R3 = CH3
 R4 = CH2CH2N(CH3)3+Cl-

21

21
 - RL و RS متباينين بس ادا release من RL اسرع
 - التفرع حسب الصياغة بختار ال group الي هم R الي فوق

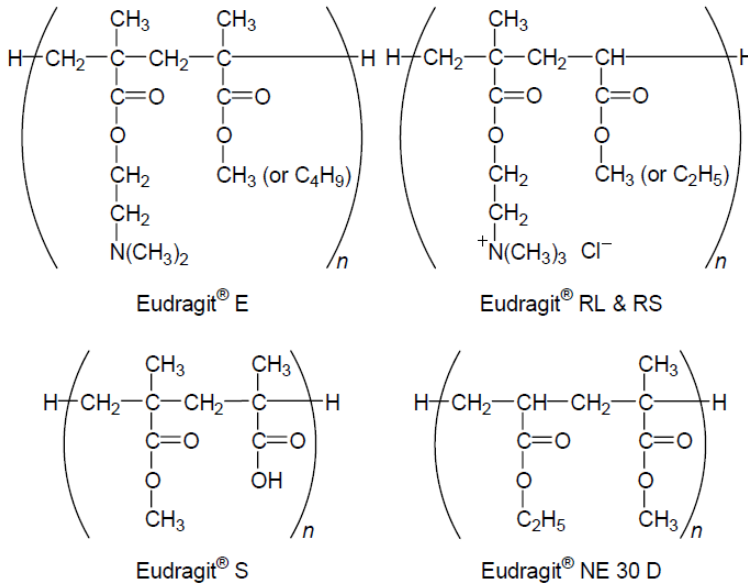

Figure 4.3 Structures of selected Eudragits®.

22

22

Plasticizer

هل تتحرك

- These are agents used to improve the quality (flexibility, adhesion) of film.
- They decrease film brittleness. ↓ همتاسة تركيز
- They should be soluble in the solvent used to dissolve the polymer.
- **Mechanism:** They ^{بدخولوا بينهم} interpose themselves on a molecular scale between the polymer strands thus permit them to move more freely. → As a particle منى molecular level عال

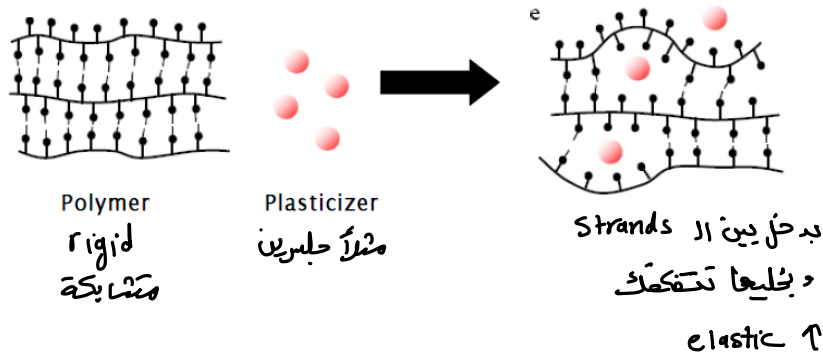

23

23

Plasticizer

هل تتشكل على شكل Tablet

water soluble water insoluble

- Examples

water soluble **Polyhydric alcohols:** Polyethylene glycols, Propylene glycol, Glycerin
 water soluble ال polymer بتساب

- **Oils:** Castor oil, coconut oil, mineral oil
- **Surfactants:** Polysorbates (Tweens), Sorbitan esters (Spans)
- **Organic esters:** Diethyl phthalate, Glyceryl triacetate (Triacetin), Triethylcitrate, acetyltriethylcitrate.

24

24

Colorants

- Pharmaceutically acceptable colors are available in both water soluble forms (dyes) and water insoluble forms (pigments)
- Pigments have advantages over water soluble colors:
 - More stable towards light *ambers bottle / مثل صل تتأكسد / الألوان الطبيعية*
 - Provide better opacity and covering power *معدل لا*
 - Optimize the impermeability of the film to vapor
- Examples: iron oxide pigments, titanium dioxide and aluminum lakes.

لون مطفي ←

يمكن blend من, colors كما وصلوا له color المطوي

25

25

Solvent

- In the past, polymers were dissolved in organic solvents (methanol, ethanol, chloroform, isopropanol, acetone, methylethylketone and methylene chloride).
- Modern techniques now rely on water as a solvent because of the disadvantages of organic solvents which include:
 - Environmental side effects
 - Safety (toxicity, explosion)
 - Financial *عالي*
 - Solvent residues in the film (impurities) *test بعد دقة ومعالجة*

براية خاصة 2

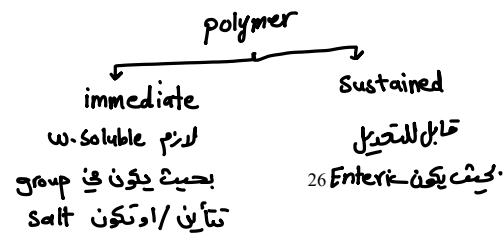

مشكلة, water بار drying يحتاج وقت طويل

26 وحرارة عالية، ويجب تستخدم حرارة عالية حتى ينقل المراج
وهيك الزمن يزيد

رجعت لا Derivatives ارجح اكتب مهن الزيادة
HPMC بتأين OH ≠
OH water soluble = يعني ≠

المبديل بخلط من الماء وواحد من organic صيدك حرارة, drying بتعمل

Aqueous polymeric dispersions → بييجي جابهم المصنع

Polymer + plasticizer + solvent

- Industrially, specialized dispersions of water insoluble polymers are frequently used.
- They permit aqueous processing of water-insoluble polymers.

methylethyl keton / CH₂Cl₂ / اسيتون / Isopropanol / chloroform / Ethanol ← organic solvent

[blindness بخل methanol ← toxic]

بسي يختاروا ال solvent بخلوا residual solvent ← gas chromatography loss indrying / الوزنوا ال اجينه دملو بال solvent
لحما بيحب وزنها ← فرق الوزن هو ال solvent

Aqueous polymeric dispersions

كله حفظ

Examples

Material trade name	Polymer	Use
Aquacoat ECD [®] , Surelease [®]	Ethylcellulose hydrophobic = sustained	Sustained release coating
Eudragit [®] RS 30 D, Eudragit [®] RL 30 D, Eudragit [®] NE 30 D	Methylmethacrylate copolymers	Sustained release coating
Kollicoat [®] SR 30 D	Polyvinylacetate	Sustained release coating
Eudragit L 30 D-55 Eudragit FS 30D	Methacrylic acid copolymers	Enteric coating
Aquacoat [®] cPD	Cellulose acetate phthalate ester	Enteric coating

28

28

weak
في قابلية
hydrolysis
Acid-Base

ذ مش w/insoluble يتكل كامل - لما يتغير من Acid-Base بصير له hydrolysis
بتحكم فيها مسبق كم تفرغ في

الاجهزة التي كانوا يصنعونها فيها السكر اسمها Coating Pan أو drum ، عبارة عن معدن مجوف بطولها أيضا tablet ويتحرك ليرة حبيبة / بدمين بنصفان Coating solu يا اما spraying او pouring (ديس) / بيلين بيكون ال coat

Film coating process

مجين بندخل hot air / في exhaust air
 ↓
 بطلع solvent الزايد
 و اذا صار في احتكاك بطلع ال impurities

- Fundamental requirements of tablet coating system include:

- 1) Adequate means of atomizing the spray liquid for application to the tablet cores
 ml/min pouring
- 2) Adequate mixing and agitation of the tablet bed
- 3) Sufficient heat input in the form of drying air for solvent evaporation
- 4) Good exhaust facilities to remove dust and evaporated solvent.

ويصهل ال coat

ما يصير تكاتف / وبصير sticking اذا ما في exhaust

Film coating process

Film is usually applied by:

- Pan coating
 - Standard coating pan
 - Perforated coating pan
- Fluidized bed (Air suspension) coating

conventional او

3 in one - mixing + granulation + drying + coating
 4 in one

Film coating process

Conventional pan system

The standard coating pan consists of a circular metal pan mounted angularly on a stand. دائريّة مثبتة وبتلف

Heated air is directed into the pan and onto the tablet bed surface and is exhausted by means of ducts positioned through the front of the pan.

في مدخل ومخرج لل h2

The coating formula is added either by **pouring** or by **spraying** (Nowadays spraying is the most commonly used method). دير بيفو اد 111 powder هخير

Spraying system is used to spray the liquid coating materials, which produce faster, and more even distribution of the solution or suspension.

اد powder بتبرك بيرة كامية

اذا بجليئة ال layer يكون كوية

اد ال سرعة عالية ال tablet ما راج لوزد كما يتفاد ال Coat بتكون في اسبي مغل راسي لا

31

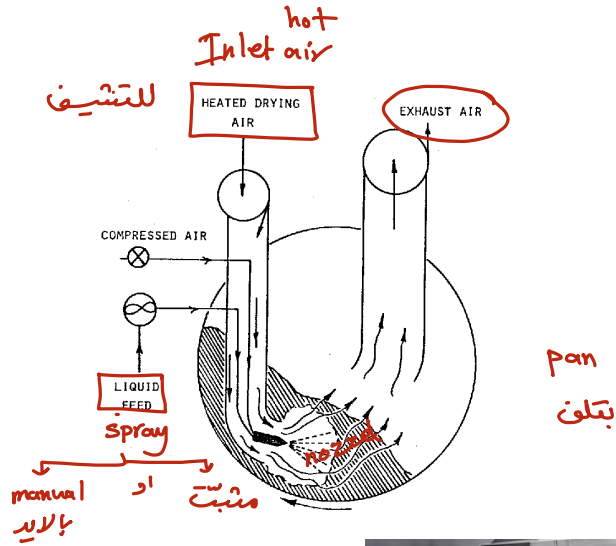
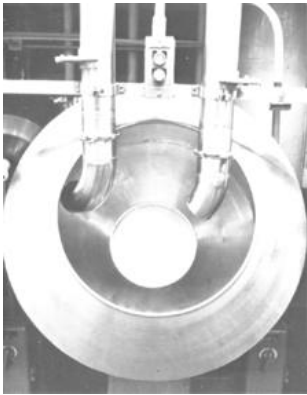

pan بتلف

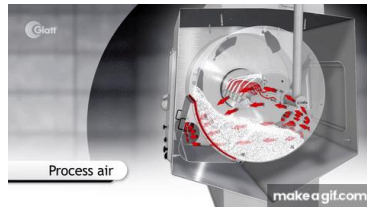

32

32

مكت راج ييجي

رفع ال حرارة ال drying / يمكن ال Film يصير منه Shrinkage وما يطي ال tablet كلما

اذا قلت المرارة ال evaporation بكل يصير في stickness او twinning (مكابت, مكبات بيغض)

- ① Conventional pan
- ② perforated pan

Film coating process

- A significant improvement in the drying efficiency of the standard coating pan is achieved by:

التي كان
ال
Conventional
pan

- ① The immersion sword زِي السيف
- ② The immersion tube system
- ③ The Pellegrini pan

33

33

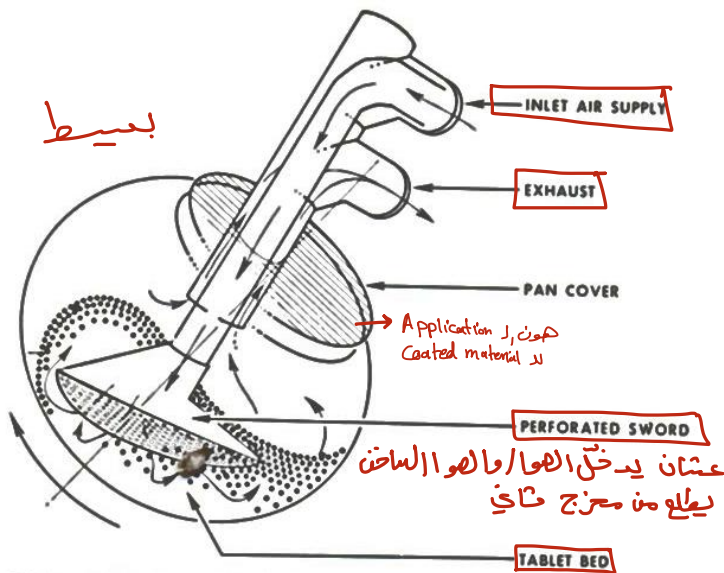

FIG. 12-7. Simplified diagram of Glatt immersion-sword system.

34

34

بنفسه sword في inlet و Exhaust ما بلقوا ، وفي spray

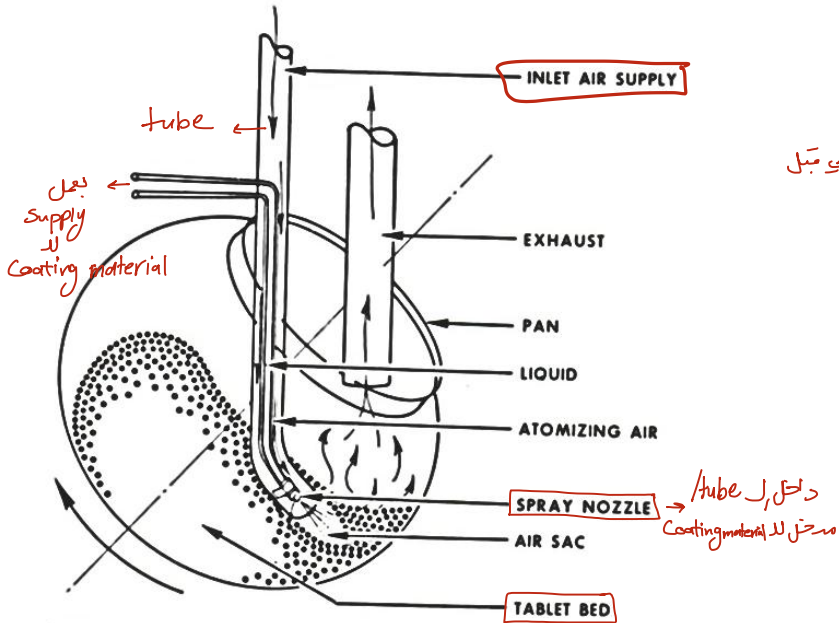

FIG. 12-8. Diagram of immersion-tube system. (From Demmer et al.⁵)

②

35

35

الاحلام الثاني حركتهم دائرية
ارتداد بطلوع وبتنزل

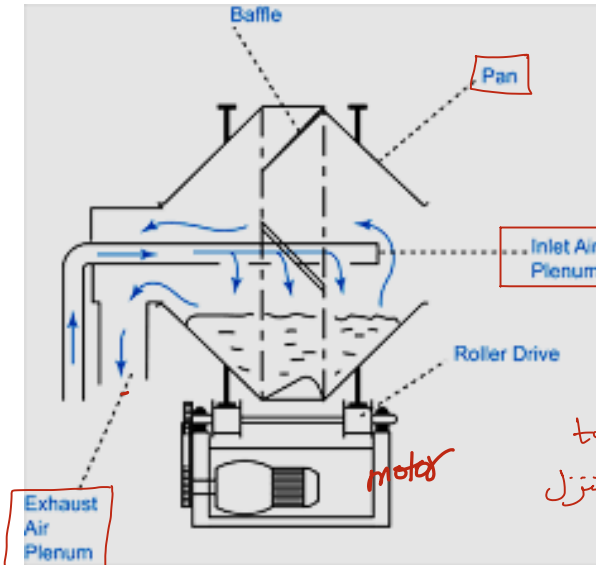

③ Pellegrini pan coater (enclosed)

↓

36 لصنع المسير لـ كما موجودة بـ cabinet



Pellegrini coating pan

36

Film coating process

Conventional كروال

② Perforated Pan Systems

التقريب
كلها
جزء منها
← المصنوع
يطلع من
عن

- In general, all equipment of this type consists of a perforated or partially perforated drum that is rotated onto its horizontal axis in an enclosed housing. Examples on this type are **Accela Cota** and **Hi-coater**. In these coaters, the drying air is directed into the drum is passed through the tablet bed and exhausted through perforations in the drum
- Driacoater** the drying air can be directed from inside the drum through the tablet bed and out an exhaust duct. The coating system is applied to the surface of the rotating beds of tablets through spraying nozzles or by pouring via distribution pipes.



زى الغنالة مع لشفافه
بتسحب المي

الدهوا بتجمع ويطالع من duct بالنها

من زى Accela و Hi coaters (لهو لاهوا يطالع
من الحيطا)

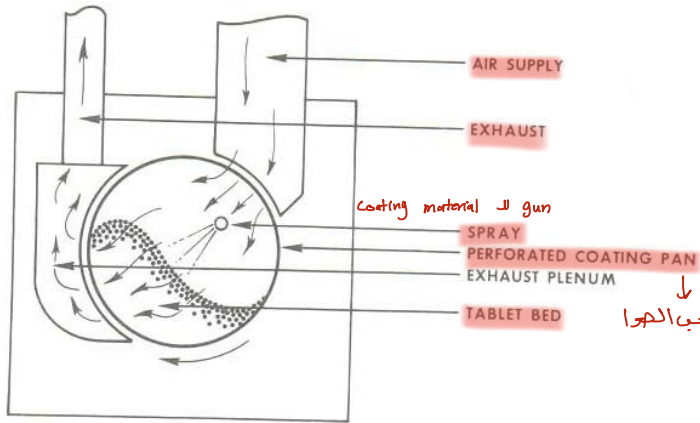

exhaust air يتسحب الدهوا ويطالع



بحسب الدهوا

FIG. 12-9. Simplified diagram of Accela-Cota system.

المصيط perforated
 او في duct بتسحب
 الهواء لبرا
 perforated نوعين

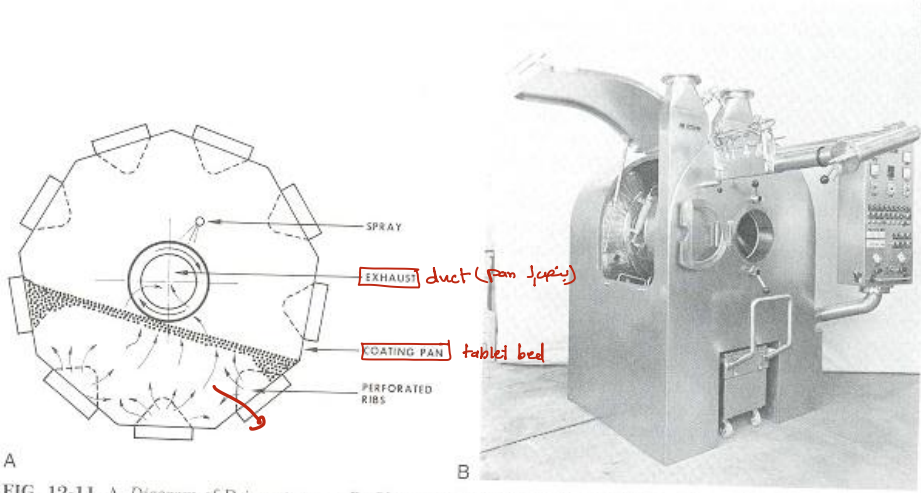

FIG. 12-11. A, Diagram of Driacoater pan. B. Glatt coater. (Courtesy of Glatt Air Techniques Inc., Ramsey, NJ.)

Film coating process

Pan coating

- 1) Charge the pan with tablets and operate the drying air and exhaust as required.
- 2) When the tablets begin to ^{Simple movement} tumble, half of the coating solution is applied in thin steady stream while exhaust is working.
- 3) Air and temperature should be controlled to allow uniform spread of solution before drying. وقت كافية

- 4) When the tablets are dried the air should be reduced and fourth of the solution is added in a thin stream.

- 5) The rest of solution is added at interval of 5 - 10 min.
 - Process variables include pan variables (shape, rotational speed and baffling), Spray variables (degree of atomization, spraying rate) and process air variables (temperature, rate ..)

↓
 ml of material / min

Continuous atomization

① وفا
 Intermittent

أو

② weak & strong atomization

اول من
 التلح
 لانه في
 هواء
 solvent
 سخان

في اول مرة
 هبطت نصف
 ال solution
 الجبين الربع
 في الربع الاخير
 بيلين اصفه
 على مراحل
 لفترة 5-10min

قواطع داخل container بتسمح ان الحركة تكون مائلة
 ديمر كل ما تسط ال tablets بيمن بعدا عن
 بتزيد فرصة تخزينهم لل coating material
 Randomization

Spray application systems

- The two basic systems used to apply a finely divided (atomized) spray onto tablets are:

- High pressure airless pumping of coating material
- Low pressure air atomized

قوة الدفع (impingement) ما في هوا
 ①- High pressure airless pumping of coating material
 ②- Low pressure air atomized
 ③- both of them

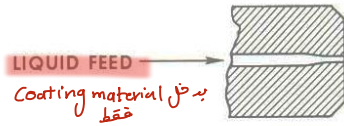

FIG. 12-14. Simplified diagram of a high-pressure, airless nozzle.

صافي يدخل للموا

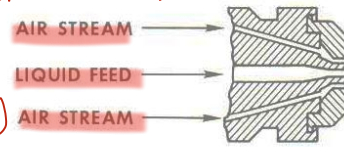

FIG. 12-15. Simplified diagram of a low-pressure, air-atomized nozzle.

نقوة عالية
 دخول الهواء وموصل
 لل Coating material يدخلوا
 نقوة عالية

قوة الهواء المضغوط : air في ②
 قوتها ليس موصلا
 ③ both of them : ضغط عادي او عالي
 من كارتونه
 41

impingement نفس ال deposition بس اسرع لانه الضغط اقل

41

Atomization: عليه البخ

Droplet formation ال droplets تتجمع على سطح كالتابلا

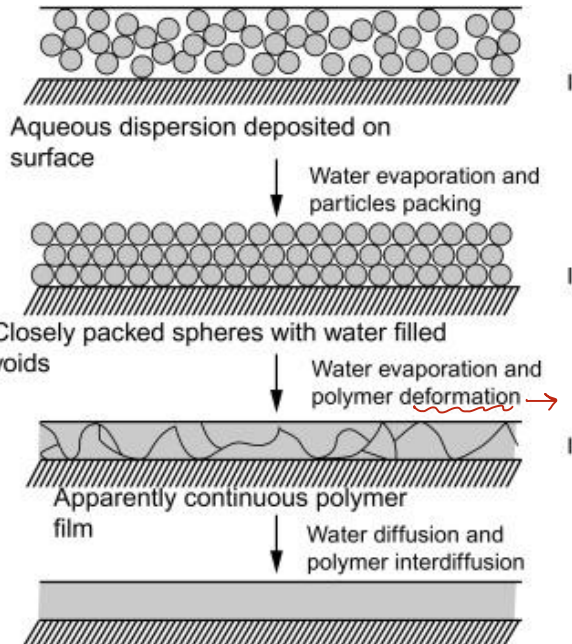
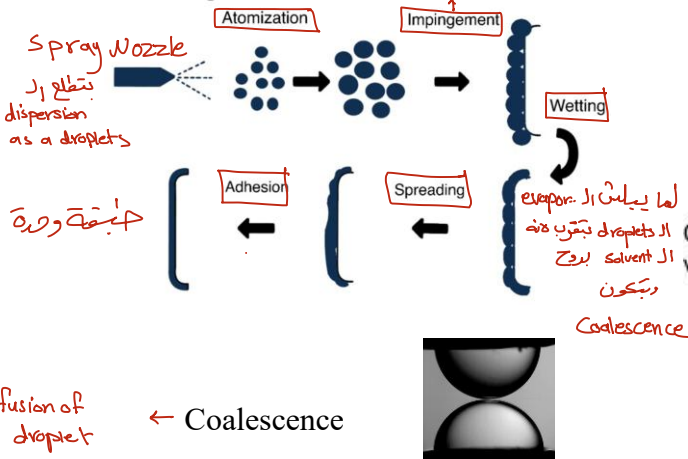

Continuous evaporation
 كان chain كل وحدة منفصلة
 بصيرك بصيروا مية اطوا بيصيرن

Deformation كامل لا Polymer
 تغير شكله الاصلي/ تراخلت كل ال chain
 و صارت دليقة وحدة بتغلف كل ال tablet

42